

# HARRINGTON HYDRANT STORZ CONNECTIONS

**HIHS™ SPECIFICATION** The Harrington Integral Hydrant Storz is threaded directly into the M&H hydrant and is internally secured with a setscrew. The HIHS™ meets or exceeds the requirements of AWWA C502 regarding material and pressure testing. For security, a Storz spanner wrench is required for cap removal (high-torque cap removal).

The Storz nozzle shall have a brass metal face and hard anodized 6061-T6 aluminum Storz ramps and lugs. The aluminum finish shall be hardcoat anodized to MIL-A-8625, Type 3, Class I, dark gray.

The Storz cap shall have hard anodized aluminum Storz ramps and lugs made of forged 6061-T6 aluminum. The center cap shall be forged 6061-T6 aluminum, not cast. The Storz Cap shall be connected to the hydrant with a 0.125" vinyl coated stainless steel aircraft cable and (2) aluminum crimps. As a security consideration, the HIHS™ Storz cap requires a Storz spanner wrench for removal. However, the Storz Hose Coupling will connect quickly and easily, by hand.

**The HIHS™ is completely Made In USA**

Once installed, the HIHS™ extends only 1.50" from the hydrant nozzle.

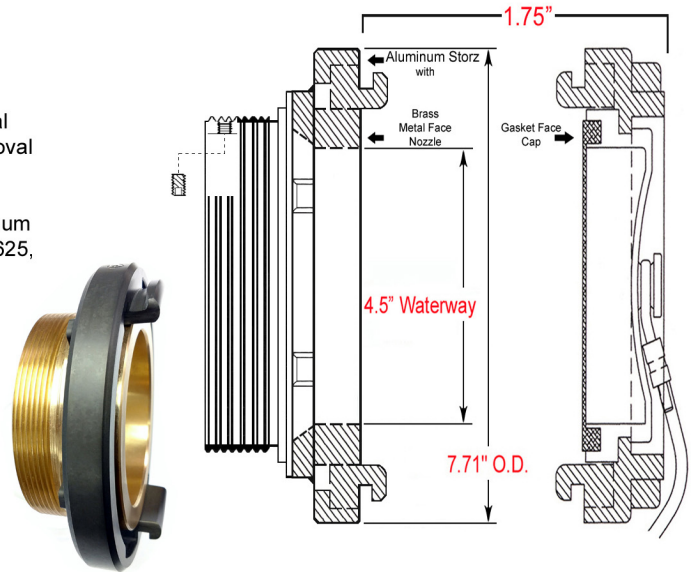

**Specify HARRINGTON STORZ**

**"HIHS-M&H-50-45"**

**- 250 psi working pressure**

**- MADE IN USA**



**Harrington**  
**STORZ CONNECT**

**2630 West 21st Street**  
**Erie, PA 16506**

**ph. 800-553-0078**  
**info@harrinc.com**



DWG No.:			<b>HIHS-M&amp;H-50-45</b>		
5" Storz Integral Hydrant Nozzle: 5 x M&H nozzle with Storz Cap and SS Cable					
Date: 01/01/23	DB: DTH	Harrington Hydrant Storz			
Not to scale	NFPA 1963 COMPLIANT	HIHS			