

HARRINGTON HYDRANT STORZ CONNECTIONS

HIHS™ SPECIFICATION The Harrington Integral Hydrant Storz is installed directly into the Waterous & American Darling hydrants and is integrally secured with the hydrant's retaining ring. The HIHS™ meets or exceeds the requirements of AWWA C502 regarding material and pressure testing. For security, a Storz spanner wrench is required for cap removal (high-torque cap removal).

The Storz nozzle shall have a brass metal face and hard anodized 6061-T6 aluminum Storz ramps and lugs. The aluminum finish shall be hardcoat anodized to MIL-A-8625, Type 3, Class I, dark gray.

The Storz cap shall have hard anodized aluminum Storz ramps and lugs made of forged 6061-T6 aluminum. The center cap shall be forged 6061-T6 aluminum. The Storz Cap shall be connected to the hydrant with a 0.125" vinyl coated stainless steel aircraft cable and (2) aluminum crimps. As a security consideration, the HIHS™ Storz cap requires a Storz spanner wrench for removal. However, the Storz Hose Coupling will connect quickly and easily by hand.

The HIHS™ is completely Made In USA

Once installed, the HIHS™ extends only 1.75" from the hydrant nozzle.

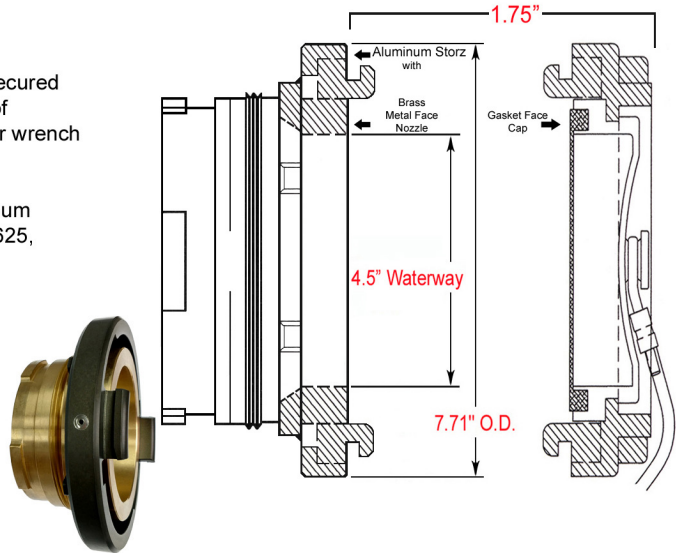

Specify HARRINGTON STORZ

"HIHS-WAT-50-45"

- 250 psi working pressure

- MADE IN USA



Harrington
STORZ CONNECT

2630 West 21st Street
Erie, PA 16506

ph. 800-553-0078
info@harrinc.com



DWG No.: **HIHS-WAT-50-45**

5" Storz Integral Hydrant Nozzle: 5 x Waterous & Amer. Darling nozzle with Storz Cap and SS Cable

Date: 01/01/23

DB: DTH

Harrington Hydrant Storz

Not to scale



NFPA 1963 COMPLIANT

HIHS